

*Great Dane*

CLASSIC REEFERS



# CLASSIC REEFERS

GREAT DANE CLASSIC REEFERS REPRESENT THE BEST EQUIPMENT INVESTMENT YOU CAN MAKE. INNOVATIVE DESIGNS AND THE VERY HIGHEST QUALITY STANDARDS PROVIDE YOU THE BEST VALUE IN REFRIGERATED TRAILERS.



## CLASSIC ALUMINUM REEFERS

Classic aluminum reefers constructed of pre-painted aluminum panels and extruded aluminum Z-post uprights are exceptionally strong. These Z-section uprights provide the highest strength-to-weight ratio and are on 12" centers from the rear of the landing gear bracing to the front. Side sheets can be flat or corrugated. Six-inch radius corners are standard.





## FRONT-END STRENGTH GREAT DANE REEFERS ARE DESIGNED TO HAVE SUPERIOR FRONT END STRENGTH

The six-inch radius corners join the sides to the front. The lower area is further protected by a 10" deep extruded aluminum impact plate across the front and wrapping around the corners to meet the bottom rails on both sides. This aluminum extrusion cannot rust, never needs paint and protects this vulnerable area. The industry's strongest bracing system secures and supports the refrigeration unit. Six 2" deep extruded aluminum Z-post uprights provide a rigid frame work for the front sheets. They are riveted on 2" centers at sheet laps, bonding the entire front together and providing maximum strength. As standard, air and electrical connections are offset to the road side and can be recessed and/or centered as options.

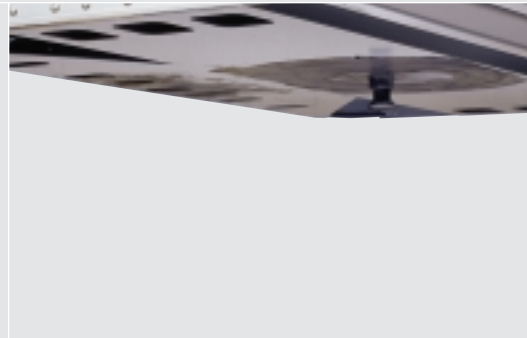
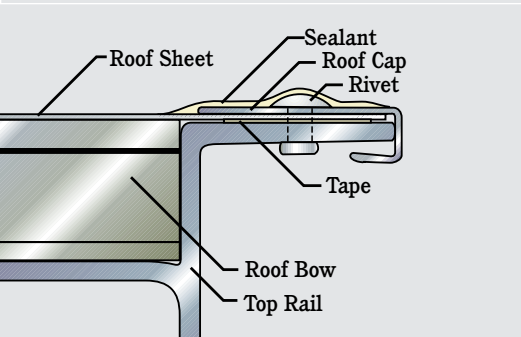

### ROOF SHEET PROTECTION

The one-piece aluminum roof sheet is installed after the roof has been insulated. The top rail roof flange is recessed from the trailer side to prevent snags and abrasions. A double-face, sealing tape is applied between the top rail flange and the roof sheet. An extruded aluminum roof cap covers the joint. Rivets on 2" centers securely compress the roof cap, roof sheet and the top rail joint. Finally, a liberal coating of neoprene is applied over the rivet heads to further insure a watertight seal. No other roof system provides this degree of protection.

### UPPER COUPLER

An optional full-width upper coupler allows tractor fifth-wheel access from any direction. The .1875" 50,000 psi approach plate turns upward, forward of impact plate to help lift and protect front end during coupling. Stainless steel lock bolts are used to securely fasten the bottom rails to the upper coupler.

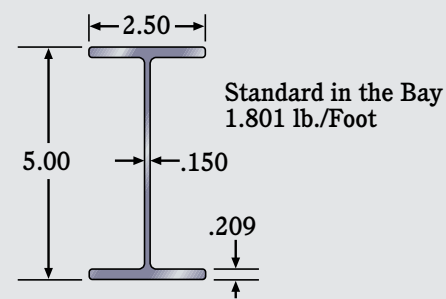

### CROSSMEMBERS

Crossmembers in the bay area, located between the landing gear and the running gear are 5" deep extruded aluminum. This increased height, from the previous 4" height, contributes to a higher live-axle floor rating. The additional height provides a stiffer and stronger member without adding additional weight.

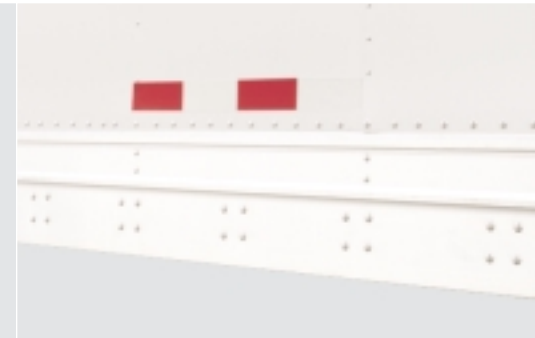

### BOTTOM RAIL

At 12", the Classic Reefer's deep bottom rail is a full inch taller than our nearest competitor. Increased strength and stiffness is achieved above the shallower 11" rails. Additionally, all crossmembers will be attached to the bottom rail with 3/8" diameter rivets; representing a 44% increase in shear strength of the attachment.

**ROLL-UP REAR DOOR** *(Optional)*  
Offered with aluminum or stainless steel exterior panel.

**.021" CORRAGATED STAINLESS STEEL PANELS**

**OPTIONAL SIDE DOORS**  
are available in various quantities and locations.

**LANDING GEAR**  
mounts spreads over five crossmembers.

**UPRIGHT SPACING**  
on 12" centers.

**12" BOTTOM RAIL**  
29% stiffer and 22% stronger than nearest competitor.

## CLASSIC STAINLESS REEFERS

Classic stainless reefers feature skin of mirror finish stainless steel as much as 6.1 times more resistant to puncture than comparably used aluminum. Stainless steel rivets fasten the panels to Z-posts located on 12" centers the entire length of the trailer. Classic stainless reefers hold their value for years down the road.





## REEFER INTERIORS

### SEAMLESS COMPOSITE LINERS SEAL MOISTURE OUT OF THE INSULATION AND ASSURE A CLEAN ENVIRONMENT FOR CARGO.

A variety of scuffband materials including aluminum, plastics and composites are available.

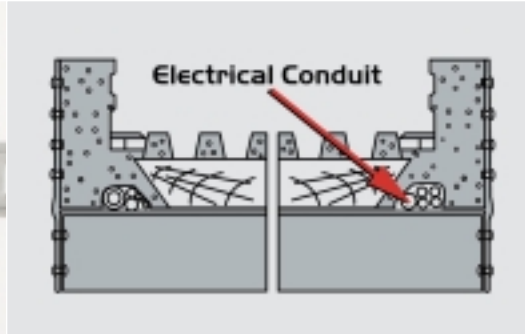
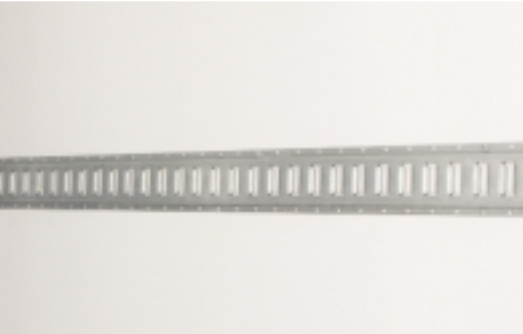

#### LOGISTIC TRACK

Numerous logistic track options are available to facilitate positive control of cargo. This is an optional feature.

#### LONG-LIFE LIGHT SYSTEM

Air and electrical lines are installed in a PVC conduit placed above the crossmembers. This design allows easier replacement of damaged crossmembers without interfering with the supply lines and will also provide better protection against road debris.



#### ALUMINUM COOLING UNIT FRAME

All frontwall cooling unit frames is constructed of heavy-duty extruded aluminum components, which save 50 pounds over steel frames. The aluminum frame will never be subject to corrosion and bleeding rust streaks that can appear around frontwall rivets.

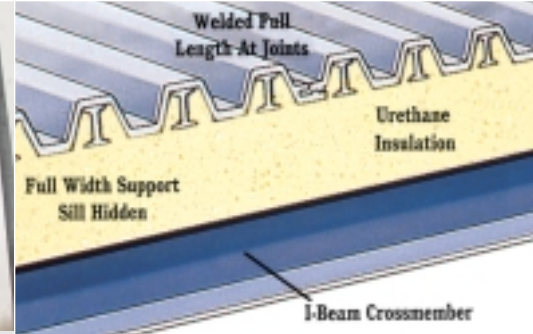

#### REEFER FLOOR SYSTEM

Great Dane offers a wide selection of floor options, all based on a time proven design. These serviceable floors can be easily cleaned and all joints are welded full length to be watertight. Heavy-duty, steel I-beam crossmembers are located on 12" centers and provide excellent support. Additionally, aluminum I-beam inserts reinforce the center 72" of the rearmost 42" of floor ducts. Floor sills in this area are of Apitong hardwood. Other I-beam lengths and closer crossmember spacings are available for special requirements.

## INTERIOR FEATURES

A FULL-WIDTH REAR GUTTER WITH THE REAR EDGE FLUSH WITH THE TOP OF THE DUCT FLOOR IS STANDARD ON REEFERS WITH SWING REAR DOORS.

Other configurations for specific applications are available. An optional overlaid logistic track facilitates positive control of cargo. Illustrated is a solid scuffband of polyvinyl. This provides a significant amount of lower wall protection.

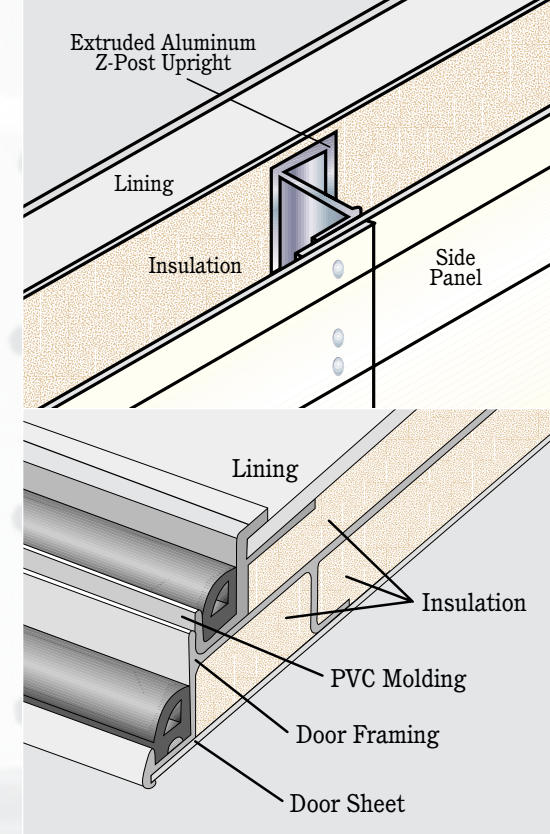

### INSULATION

Great Dane reefers have no metal-to-metal contact from the interior to the exterior of the floor, wall and ceiling. Floors are injected with frothed-in-place urethane on either side of a center dam between each set of floor sills. These two "shots" fill the floor cavities and the foam turns up the walls. Additional injections from the top are measured so the rising foam hits a covering of polyethylene and turns inward between roof bows. Lastly, the roof cavity is injected near the center to complete the foaming. A visual inspection for voids is made before the roof sheet is installed.

A WIDE VARIETY OF EXTRUDED ALUMINUM FLOORS IS AVAILABLE IN STANDARD AND HEAVY-DUTY RATINGS, AS WELL AS, STANDARD AND SLIP-RESISTANT SURFACES.



## REAR IMPACT GUARD

A MASSIVE CHANNEL RUNS ACROSS THE REAR PROVIDING PROTECTION FROM DOCKS OR GROUND-LEVEL OPERATED FORK TRUCKS.

All lights are fully recessed and securely protected. A steel box encloses and protects the front side and wiring. A rear underride guard, meeting federally mandated standards, is securely back braced. Conspicuity tape on the horizontal member is recessed to prevent abrasion. Slip-resistant material on it's top is designed to increase foothold traction. Rubber dock bumpers are standard.



### REAR FLOOR GUTTER

The narrower rear floor gutter has been reduced from 3.5" to 2.5" wide, allowing for a less obstructive transition into the trailer and reducing the chance dock-plates will become wedged into the gutter. The narrower design requires less wood structure for support and also saves 14 pounds.



### CENTER CAM LOCK

Great Dane pioneered the use of a cam lock in the door centers as standard. A cam grip attached to a lock rod grips a special flange on the opposite door. This unites the door seals and provides a three-point rear door locking mechanism. Two lock rods per door provide even a stronger seal for extreme operations.



### BOTTOM RAIL / REAR FRAME JOINT

As an option, the joints of the bottom rails and the rear frame can be further reinforced with a specially shaped stainless steel overlay.



### HINGES

Totally rust-free extruded aluminum hinges are fastened to the rear doors by four .375" stainless steel bolts making hinge replacement effortless. Phenolic bushings are inserted into the extruded aluminum hinge pin-hole to ensure smooth-swinging, wear-free door usage for years down the road.

## ACCESS

GREAT DANE PROVIDES AS STANDARD ON SIDE OR REAR SWING DOORS A VERTICAL GRAB HANDLE TO PROPERLY CENTER ONE'S WEIGHT WHEN ENTERING OR EXITING THE TRAILER.

On all roll-up rear doors is a retractable step system and a grab handle integral within the rear frame.



## REEFER REAR END

Reefer rear frames are specially designed and constructed of rustproof satin-finish stainless steel. All hinges, lock rods and door hardware are fully recessed within the 3" deep door posts. All rear frame fasteners and hinge pins are stainless steel. A full-width rear gutter across the top rear diverts roof drainage to the sides. When closed, doors are completely restrained within the protection of the rear frame, even if all hinges are damaged or removed.





## SUSPENSION

GREAT DANE IS STANDARD ON A TEN-STUD HUB-PILOTED WHEEL-END SYSTEM AND A FOUR SPRING SUSPENSION.

Air-spring suspension is optional and protects sensitive loads and adds life to certain vehicle componentry while improving the ride.



### VENT ACCESS

A vent access system is provided as standard with all front corner vents. This consists of two steps and a vertical grab handle centered to properly position oneself for adequate balance.



### VENT DOORS

Available as an option, vent doors are fully insulated with urethane foam. Front radius and flat rear vent doors are formed of expanded vinyl. The vinyl cleans easily and forms a perfect fit. Their double seal prevents costly air leaks.



### VENT HARDWARE

All hardware is anodized aluminum with stainless steel fasteners. The locking handle has two nylon contacts to provide smooth, but positive, operation.



### LANDING GEAR

Great Dane's GD70 Fast Gear has the highest lift capacity in the industry. Each leg is strongly braced to withstand forces from the sides, front or rear. Landing gear mounts are recessed from the side rails for piggyback adaptation. Shock-mounted sand shoes are standard and reduce stresses transferred to the crossmembers by 50% over conventional-type sand shoes. If required, these rubber pads may be replaced easily, without replacing the entire sand shoe.

**LIGHT PROTECTION**  
Top rail marker and clearance lights are fully recessed.

**SIDES**  
Pre-painted white aluminum panels. Upright spacing to meet individual requirements.

**SIDE DOOR**  
Doors are of frame-type construction and are fabricated as the trailer is produced to achieve precise fit..

**RAMP**

**LANDING GEAR**  
has the highest lift capacity in the industry



## MULTI-TEMP SPECIAL PURPOSE REEFERS

Many reefer operations require very unique and flexible compartmentalization of the available space. Great Dane specializes in meeting these needs. Multiple side doors. Installation of plumbing for various remote evaporator locations. Moveable bulkheads. Side door platforms, ladders and ramps.





**CENTER PARTITIONS**  
USING A DUAL EVAPORATOR  
HOST UNIT AND ONE REMOTE  
EVAPORATOR, AND A CENTER-  
PARTITION BULKHEAD SYSTEM  
ALLOW THE TOTAL INSIDE AREA  
TO BE DIVIDED BETWEEN AS  
MANY AS THREE CONTROLLED  
TEMPERATURES AND AN  
AMBIENT SECTION.

This achieves precise control of temperatures, while providing extreme flexibility to reconfigure for various types of hauls. With all cargo coming off the rear with a walk ramp, possibility of injury is reduced.



**VERSATILITY OF RECONFIGURATION**

The versatility of reconfiguration allows maximum productivity. Temperatures can be set to match load requirements.



**SIDE DOOR PLATFORM AND LADDER**



**PINTLE HOOKS**

Precisely located pintle hooks, chain bars and air and electrical connections provide for a safe multiple trailer operation.



**TIGHT-FITTING CLOSURES**

Tight fitting closures join the ceiling liner to the wall lining, as well as to the front.

**WALK RAMPS PROPERLY INSTALLED,  
REDUCE WORKMAN COMPENSATION  
CLAIMS BY PROVIDING A SAFER WAY  
OF REMOVING CARGO, WHETHER OFF  
THE REAR OR OUT OF SIDE DOORS.**

Installation must be precise, so as not to interfere with suspensions and other components. Plastic strip curtains, as well as, tri-fold rear doors help maintain interior temperature while unloading.



**GREAT DANE INNOVATION**

Great Dane's Engineering Department, including a research and development staff, work closely with customers to solve problems with innovative specs.





## **BULKHEAD**

**MOVEABLE BULKHEADS  
ALLOW FOR THE SIMPLEST  
FORM OF MULTI-TEMP  
COMPARTMENTALIZATION.**

They can be moved or removed quickly to facilitate various loads and backhauls.



### **CENTER BULKHEAD SECTIONS**

Center bulkhead sections are readily relocatable and can be stored against the sidewall for conventionally loaded back hauls.

### **INSIDE DOORS**

Doors may be unlocked from inside — if someone is inadvertently locked in.

### **ROLL-UP DOOR FITS INTO FALSE CEILING**

### **REMOTE EVAPORATOR**

Cieling-mounted

CLASSIC REEFERS